

AC MOTOR FAN DRIVEN PRODUCTS

HEAT EXCHANGERS

HEAT-EXCHANGERS



2000K & KBV SERIES

HPV SERIES I



HPV Series II

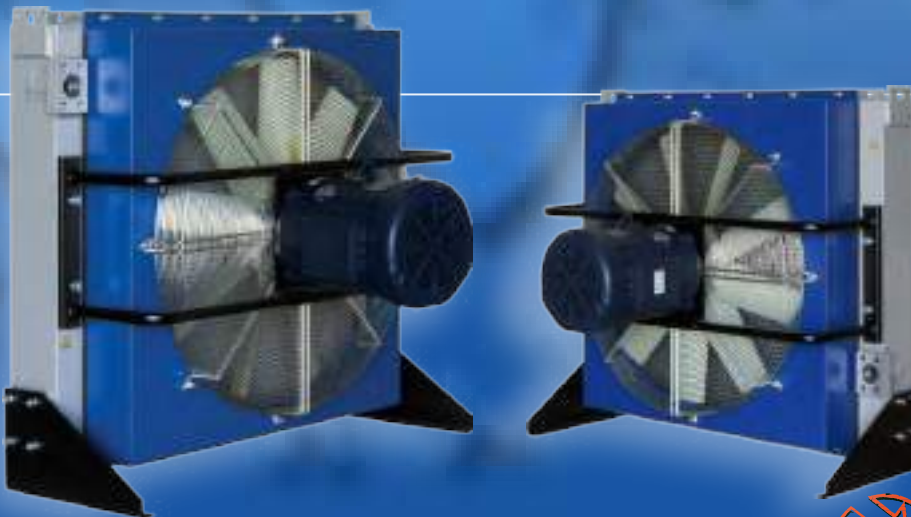

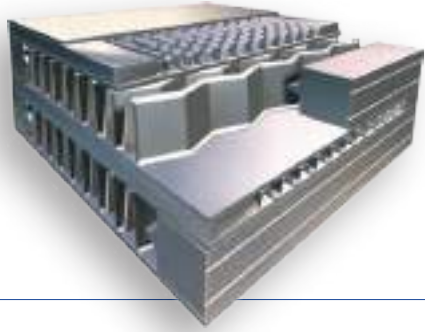

BAR & PLATE TECHNOLOGY

Aluminum Bar & Plate construction is the most advanced heavy duty technology available today.

This design has several significant features:

Compact Performance: Up to 50% smaller than traditional fin & tube construction.

Rugged Construction: 1/4" Thick bars protect the fluid channels from damage.

Serviceable: Bars extend to fin edges allowing high pressure washing.

Non-Louvered Air Fins : resist fouling.

MOTOR OPTIONS

EMMEGI offers a wide selection of standard and optional motor types.

Standards include NEMA, IEC, and Custom frames.

Optional motors include: Explosion Proof, 575V

Washdown, ATEX and many others.



OIL CONNECTIONS



EMMEGI oil coolers are stocked with BSP Parallel thread oil connections.

This allows us to draw inventory from our other Worldwide locations as needed.

Product shipped from our US facility include SAE J514 37° flare adaptors.

Both straight and 90° fittings are standard.

A wide selection of optional types and sizes also available.

OPTIONAL TEMPERATURE / FAN CONTROLS

All Models include a temperature sensor port in the cooler manifold.

Fan/Motor temperature controls are available in both fixed and adjustable versions.

Low cost and easy to apply, these switches assure proper temperature control.



CUSTOM DESIGNS / WORLDWIDE SUPPORT

EMMEGI has Manufacturing facilities and sales support worldwide.

In today's global marketplace, EMMEGI can provide seamless support to our Products.

With reasonable quantity, product can be designed to specific customer specifications.

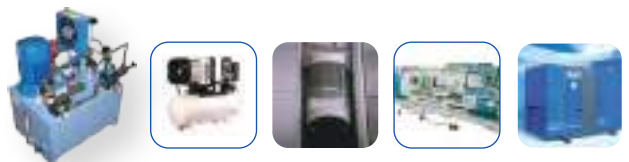

Built-in Internal Bypass Checkvalve

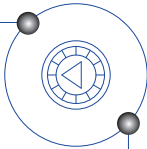

Cartridge valve type 2

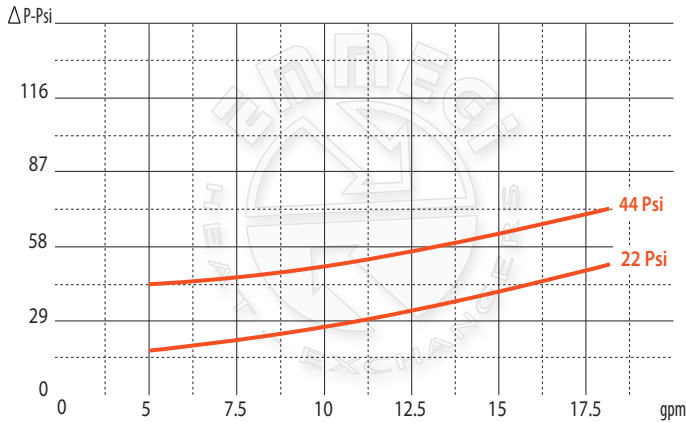

Cartridge valve type 3

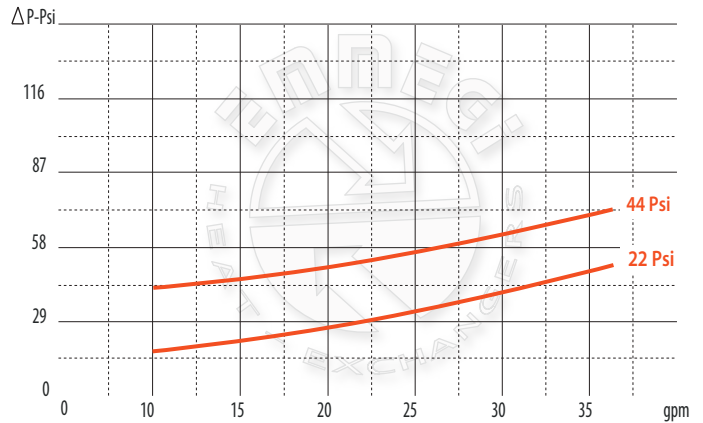

The integrated bypass checkvalve helps protect the hydraulic system and oil cooler from excessive back pressure.

Two primary operating conditions are :

- Cold Weather Start-up
- Intermittent Flow Surges

The fully integrated cartridge style valve eliminates the need to add an external valve and the related fittings and hoses. It may be removed for inspection and service.

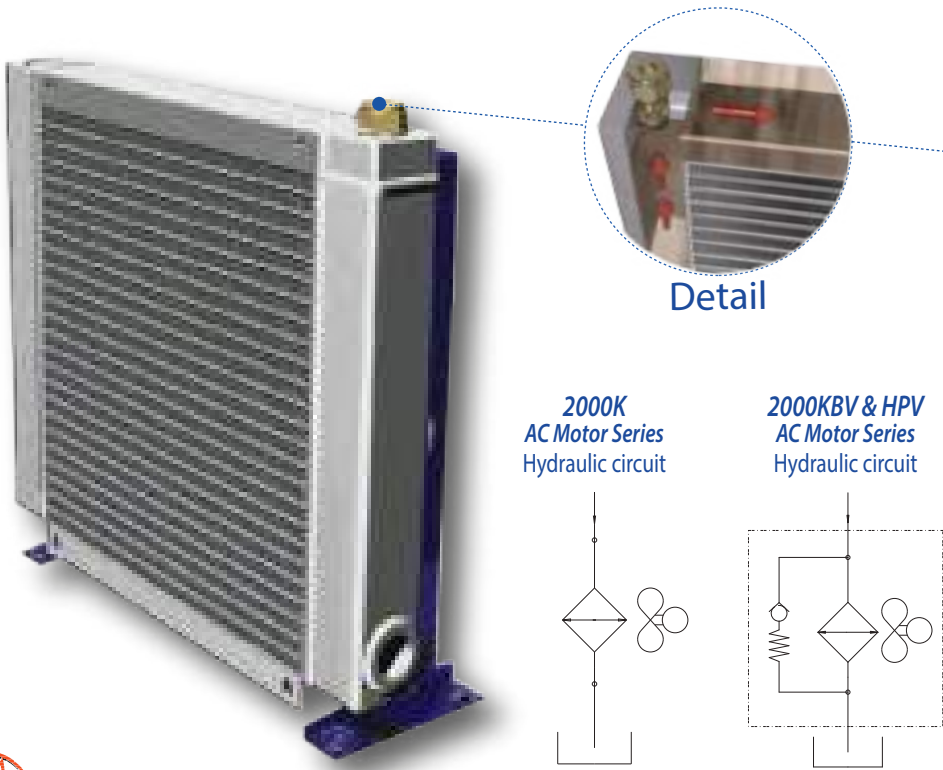

Detail

2000K
AC Motor Series
Hydraulic circuit

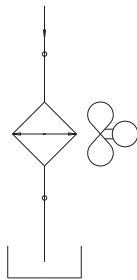

2000KBV & HPV
AC Motor Series
Hydraulic circuit

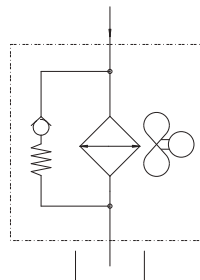

Model	Cartridge valve type
All 2000KBV	2
HPV 12 - 24	2
HPV 30 - 250	3



HEAT-EXCHANGERS

Performance Data - AC 2000K & HPV Series I



Horsepower Heat Rejection @ 50°F ETD

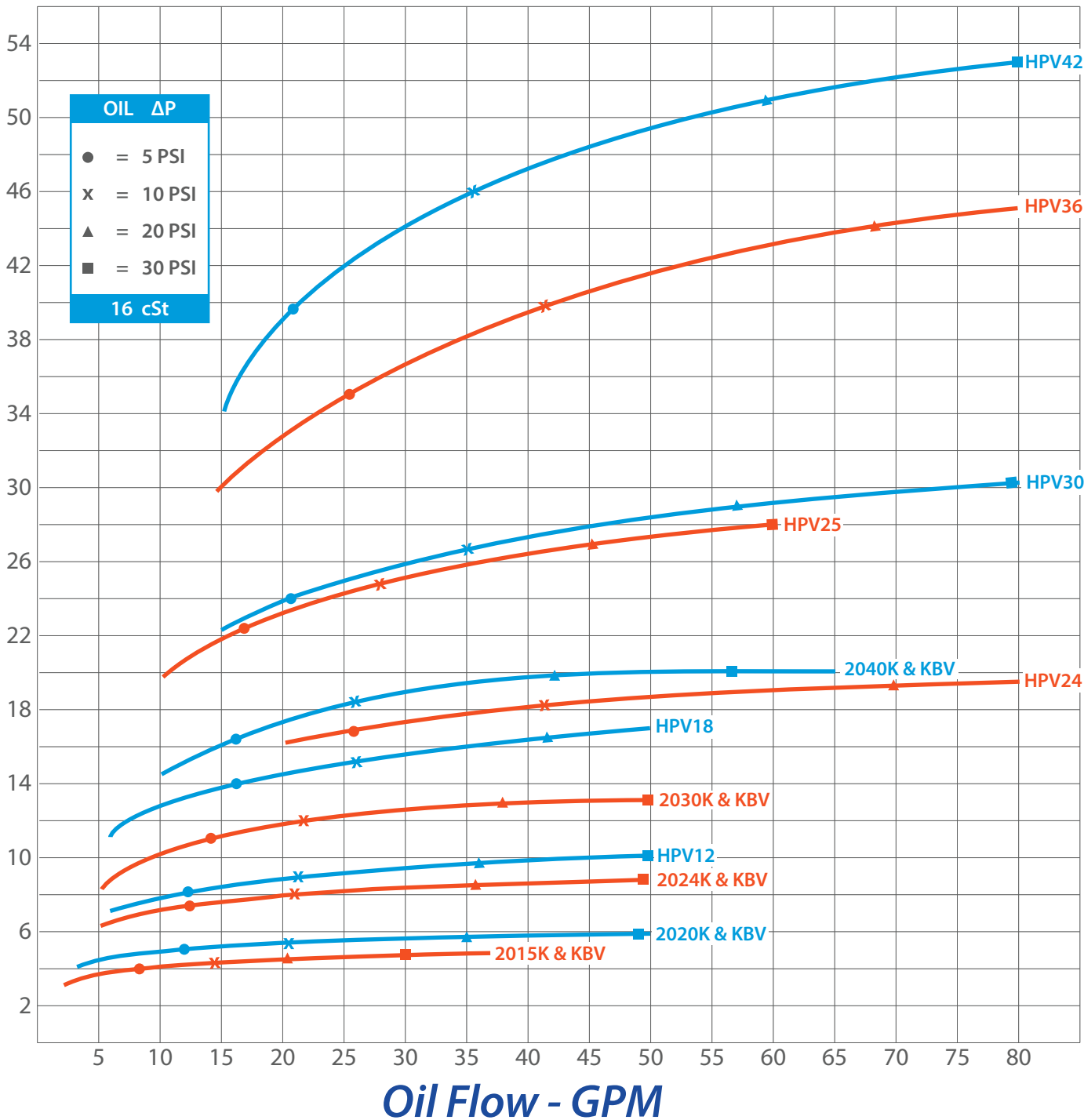

NOTES - Performance is reduced by 1/6 for 50Hz service.

Pressure drop based on ISO VG 46 oil at typical operating temperature.

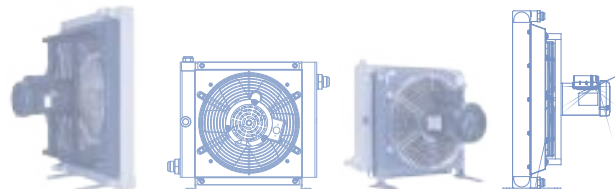

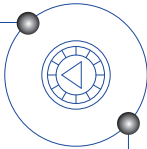

Horsepower Heat Rejection @ 50°F ETD

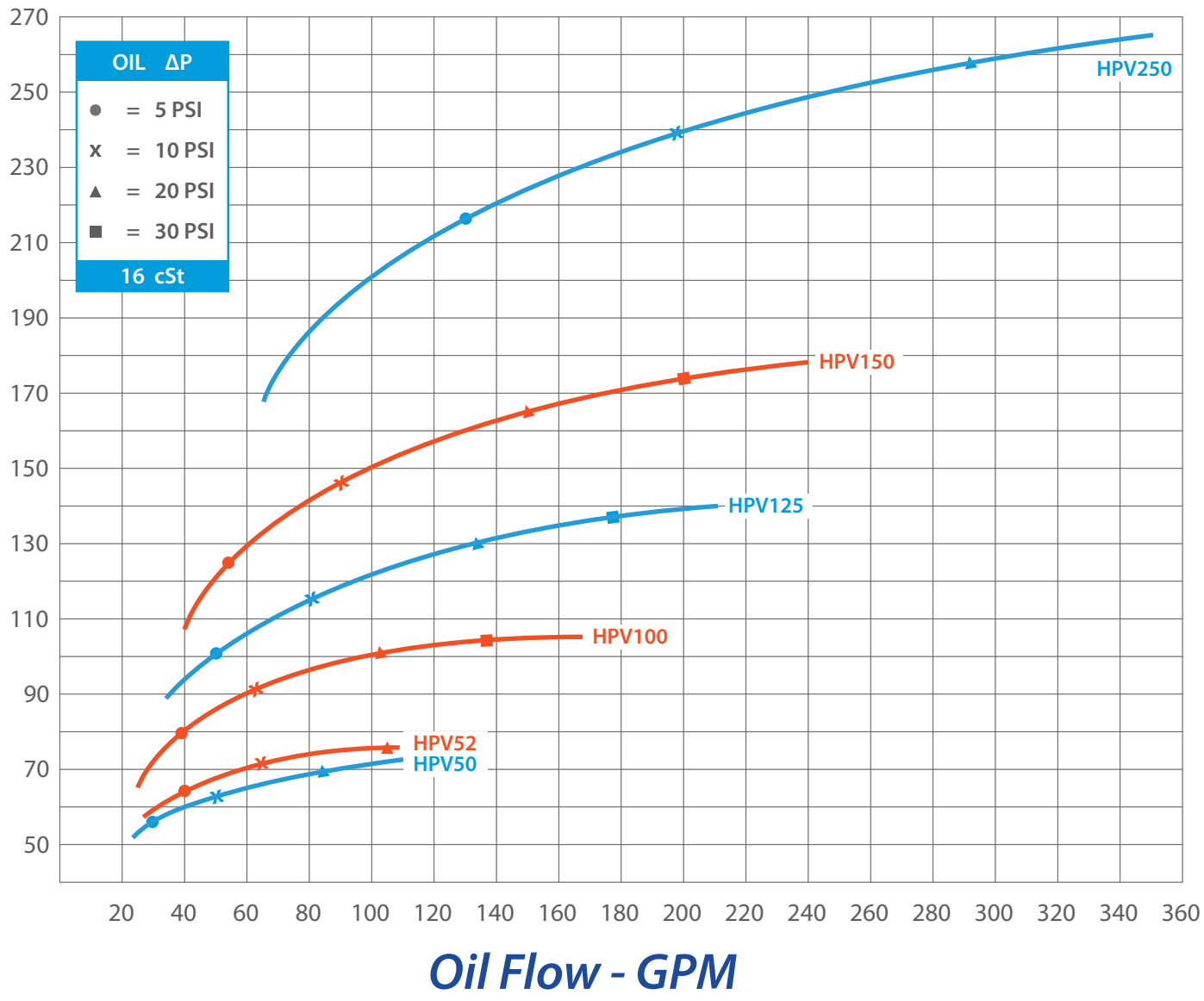

HEAT-EXCHANGERS

Correcting Heat Removal for Cooler Selection from Curve

$$\text{Horsepower Heat Load} \times \frac{50^\circ\text{F}}{\text{Desired ETD } ^\circ\text{F}} = \text{Corrected Horsepower Heat Removal for Curve Selection}$$

Correcting Curve to Actual Heat Removal

$$\text{Horsepower (FROM CURVE)} \times \frac{\text{Desired ETD } ^\circ\text{F}}{50^\circ\text{F}} = \text{Corrected Horsepower Heat Removal}$$

Entering Temperature Difference

$$\text{ETD } ^\circ\text{F} = \text{Oil Inlet Temperature } ^\circ\text{F} - \text{Air Entering Temperature } ^\circ\text{F}$$

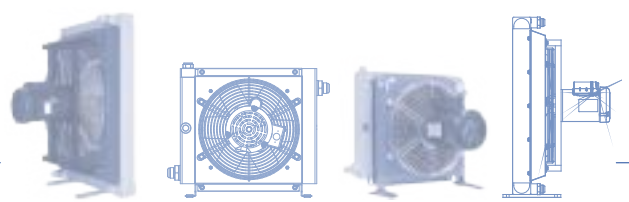

2000K & KBV Series Heat Exchangers



2000 KBV
(WITH BYPASS)

2000 K
(WITHOUT BYPASS)

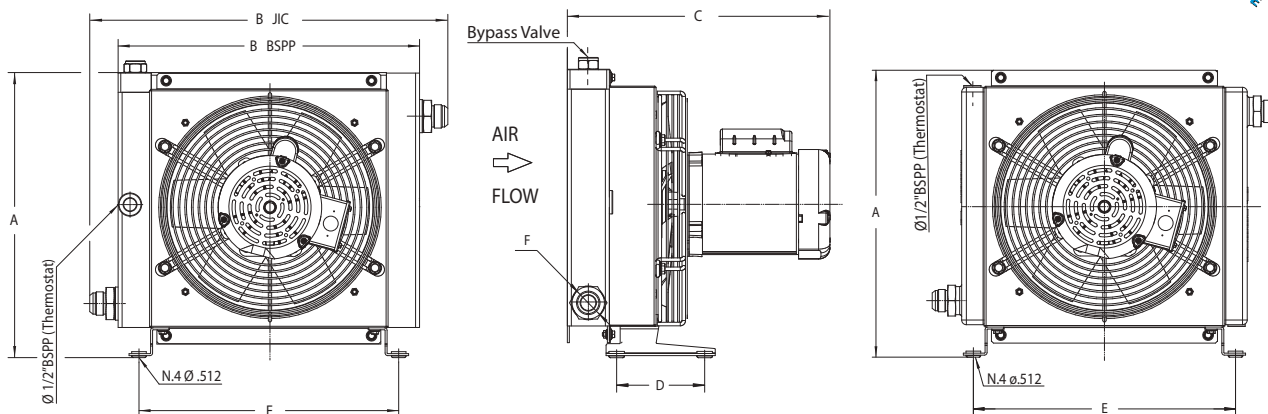

MODEL	Unit of Measure	Overall Dimensions					Mounting		Oil Connections		Tech Data				
		A	B*		C Approx.		D	E	F		dB(A)	Net Weight. Lbs.			
			BSPP	JIC	Single Phase 1NS	Three Phase 3IS			BSPP	JIC		1 Phase K	3 Phase K	1 Phase KBV	3 Phase KBV
2015 K/KBV	(inch)	11.98	12.60	15.36	13.61	13.74	4.92	10.90	1" Internal	# 16 External	78	35	25	37	27
	(mm)	304	320	390	346	349	125	277				36	26	38	28
2020 K/KBV	(inch)	11.98	12.60	15.36	14.32	14.45	4.92	10.90			78	36	26	38	28
	(mm)	304	320	390	364	367	125	277							
2024 K/KBV	(inch)	14.40	14.96	18.51	14.32	14.45	4.92	12.87	78	42	32	45	35		
	(mm)	366	380	470	364	367	125	327							
2030 K/KBV	(inch)	16.91	17.51	21.08	15.08	15.34	4.92	15.43	85	46	45	49	48		
	(mm)	430	445	535	383	390	125	392							
2040 K/KBV	(inch)	21.00	21.25	24.41	16.38	15.88	4.92	19.17	1.25" Internal	# 20 External	79	59	61	63	65
	(mm)	526	540	620	416	403	125	487				59	61	63	65

Ordering Code

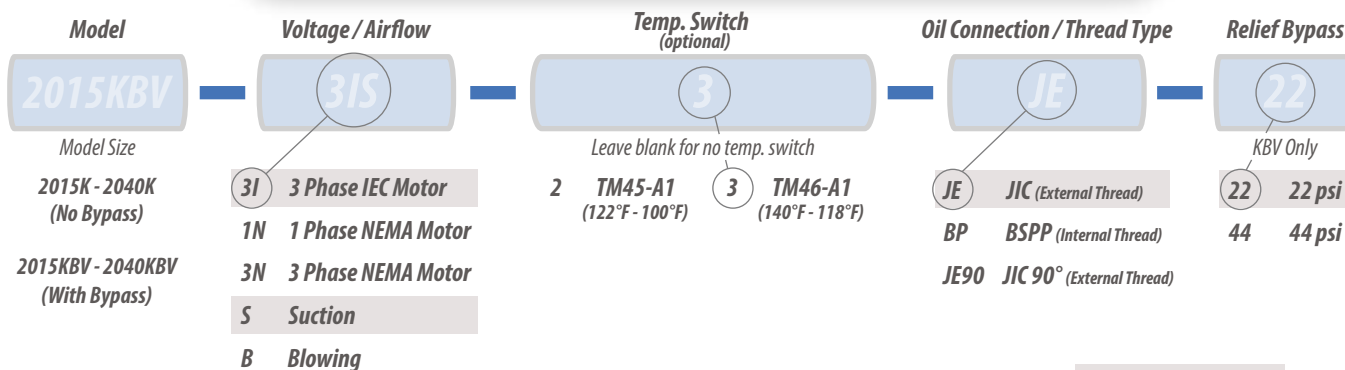

Indicates Standard Selection

Emmegi stocks most adaptors to increase or reduce the fittings by one size. Additional cost may apply, consult factory. Examples:

JE90 = 90° Adaptors

JE12 = JIC #12 Adaptors



HEAT-EXCHANGERS

HPV 12 - 52 Series I Heat Exchangers

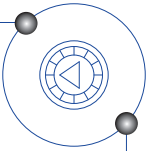

HPV 42 - 52

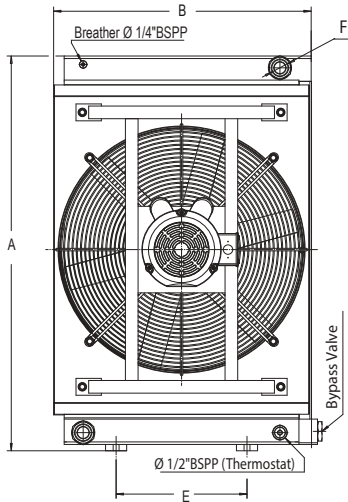

AIR
→
FLOW

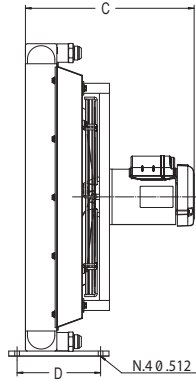

HPV 12 - 36

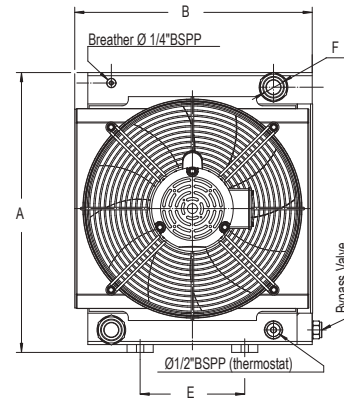

MODEL	Unit of Measure	Overall Dimensions				Mounting		Oil Connections		Tech Data		
		A	B	C Approx.		D	E	F		dB(A)	Net Weight. Lbs.	
				Single Phase 1NS	Three Phase 3NS			BSPP	JIC		1 Phase	3 Phase
HPV 12	(inch)	15.74	14.05	15.19	15.35	7.87	5.90	1" Internal	# 16 External	75	41	42
	(mm)	400	357	386	390	200	150					
HPV 18	(inch)	20.07	17.91	16.00	15.50	7.87	7.87	1.25" Internal	# 20 External	78	59	57
	(mm)	510	455	406	394	200	200					
HPV 24	(inch)	21.06	17.91	17.29	16.79	9.84	7.87	1.25" Internal	# 20 External	78	74	71
	(mm)	535	455	439	426	250	200					
HPV 25	(inch)	25.59	23.82	15.95	15.95	7.08	15.74	1.50" Internal	# 24 External	79	84	80
	(mm)	650	605	405	405	180	400					
HPV 30	(inch)	26.97	18.46	17.09	17.09	9.84	7.87	1.50" Internal	# 24 External	80	94	89
	(mm)	685	469	434	434	250	200					
HPV 36	(inch)	30.90	24.17	18.20	18.18	9.84	12.20	1.50" Internal	# 24 External	85	134	129
	(mm)	785	614	462	462	250	310					
HPV 42	(inch)	36.81	24.02	18.60	18.55	9.84	12.20	1.50" Internal	# 24 External	85	174	166
	(mm)	935	610	472	471	250	310					
HPV 50	(inch)	37.59	28.64	21.59	21.09	9.84	15.74	1.50" Internal	# 24 External	85	223	246
	(mm)	955	727	548	536	250	400					
HPV 52	(inch)	37.59	28.67	22.44	21.94	9.84	15.74	1.50" Internal	# 24 External	85	245	240
	(mm)	955	728	570	557	250	400					

Ordering Code

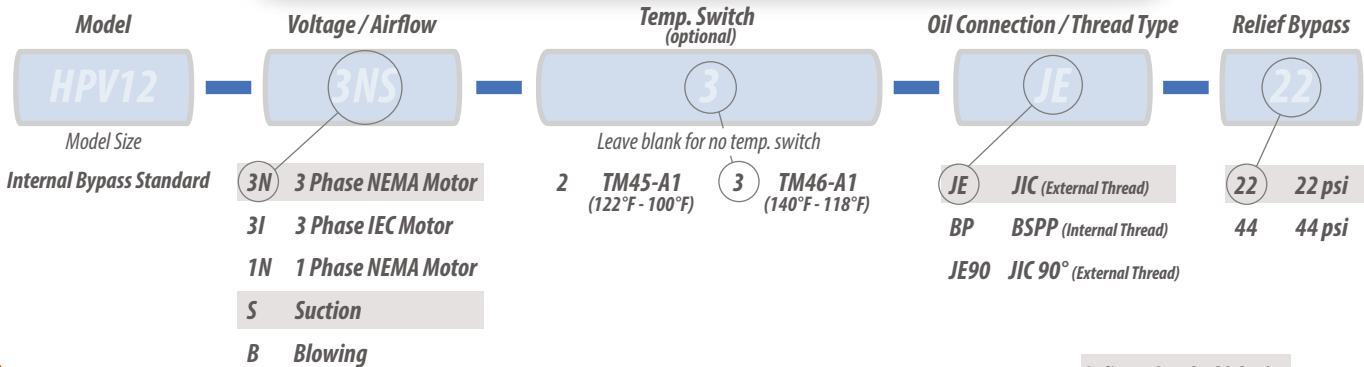

HEAT-EXCHANGERS

HPV 100 - 250 Series II Heat Exchangers

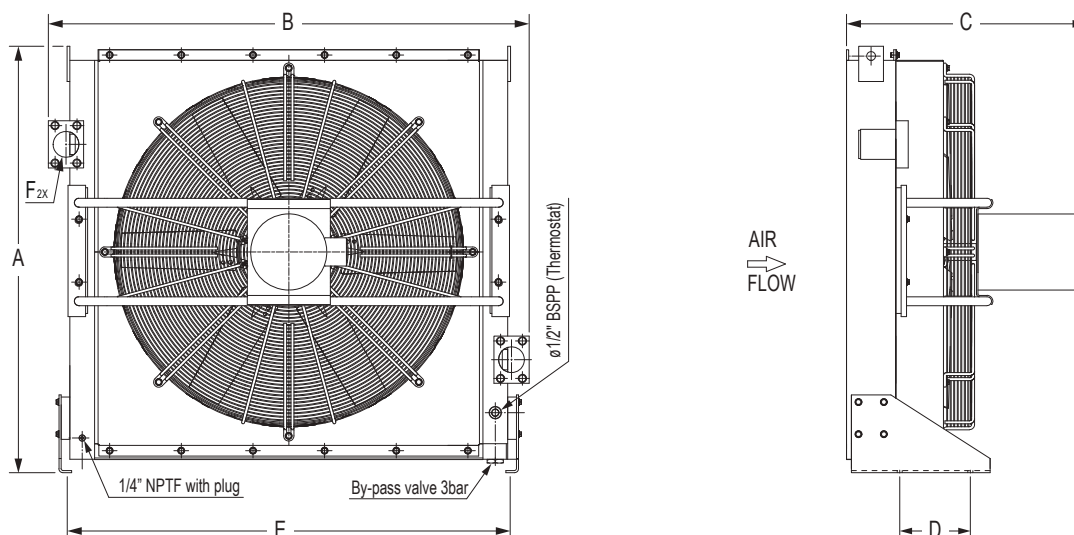

MODEL	Unit of Measure	Overall Dimensions				Mounting		Oil Connections	Tech Data	
		A	B	C Approx.		D	E	F	dB(A)	Net Weight Lbs. 3 Phase AC Fan Motor
				Three Phase 3NS	Three Phase 3IS					
HPV 100	(inch)	39.13	43.70	24.00	26.45	7.87	41.65	2" SAE Flange	94	370
	(mm)	994	1110	864	672	200	1058			
HPV 125	(inch)	40.20	44.88	29.50	30.00	7.87	43.62	3" SAE Flange	98	450
	(mm)	1021	1140	749	762	200	1108			
HPV 150	(inch)	47.56	53.62	29.12	29.66	7.87	49.53	3" SAE Flange	99	555
	(mm)	1208	1362	740	753	200	1258			
HPV 250	(inch)	66.61	52.36	32.96	-	10.00	49.37	3" SAE Flange	101	800
	(mm)	1692	1330	837	-	254	1254			

Ordering Code

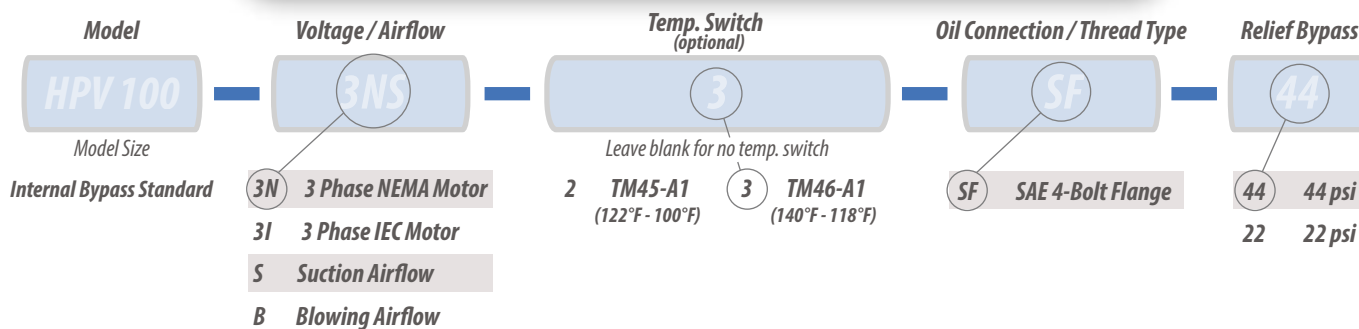

Indicates Standard Selection

TECHNICAL DATA FOR ALL 2000 K/KBV & HPV MODELS

Compatible fluids

- Mineral Oils : HL & HLP.
- Water - Oil Emulsion.
- Water - Glycol.
- Consult Factory for other fluids.

Ratings

- Operating Pressure : 280 PSI
- Test Pressure: 500 PSI
- Maximum Operating Temperature: 248°F



HEAT-EXCHANGERS

ACM SERIES MOTOR DATA

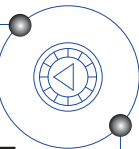

EMMEGI Model	Catalog Motor Code	HP KW @ 50Hz	RPM	Motor Frame	Operating Voltage - Frequency	Phase	Thermal Protection	Full Load Amps
2015K & KBV 2020K & KBV	1NS	0.33	3450	NEMA 56SC	115-208-230V 60Hz	1	No	5.6 / 2.8
	3IS	0.25	3430	IEC D63C	230/460V 60Hz	3	No	0.84 / 0.42
0.187		2760	200/400V 50Hz		1.0 / 0.5			
2024K & KBV HPV 12	1NS	0.33	3450	NEMA 56SC	115-208-230V 60Hz	1	No	5.6 / 2.8
	3IS	0.33	3430	IEC D63C	230/460V 60Hz	3	No	1.1 / 0.55
0.25		2760	200/400V 50Hz		1.3 / 0.65			
2030K & KBV	1NS	0.5	3450	NEMA S56C	115-208-230V 60Hz	1	No	7.0 / 3.5
	3IS	0.5	3425	IEC D71C	230/460V 60Hz	3	No	1.6 / 0.8
0.37		2790	200/400V 50Hz		1.9 / 0.95			
2040K & KBV HPV 18 HPV 24	1NS	0.5	1725	NEMA S56C	115-208-230V 60Hz	1	No	8.0 / 4.0
	3NS	0.5	1725	NEMA S56C	208-230/460V 60Hz	3	No	2.0 / 1.0
	3IS	0.5	1695	IEC D71C	230/460V 60Hz	3	No	1.8 / 0.9
0.370		1380	200/400V 50Hz		1.8 / 0.9			
HPV 25	1NS	0.75	1725	NEMA 56C	115-208-230V 60Hz	1	Auto	10.8 / 5.4
	3NS	0.75	1725	NEMA 56C	208-230/460V 60Hz	3	No	2.8 / 1.4
HPV 30	3IS	0.75	1690	IEC D71C	230/460V 60Hz	3	No	2.5 / 1.25
		0.56	1390		200/400V 50Hz			2.9 / 1.45
HPV 36	1NS	1.5	1725	NEMA 56C	115-208-230V 60Hz	1	No	17.2 / 8.6
	3NS	1.5	1740	NEMA 56C	208-230/460V 60Hz	3	No	5.0 / 2.5
1.12		1450	190/380V 50Hz		4.4 / 2.0			
HPV 42	3IS	1.5	1725	IEC D90SC	230/460V 60Hz	3	No	4.2 / 2.1
		1.12	1450		200/400V 50Hz			4.8 / 2.4
HPV 50	1NS	2.0	1725	NEMA 56C	115-230V 60Hz	1	No	18.4 / 9.2
	3NS	2.0	1725	NEMA 56C	208-230/460V 60Hz	3	No	6.2 / 3.1
HPV 52	3IS	2.0	1710	IEC D90C	230/460V 60Hz	3	No	5.4 / 2.7
		1.49	1425		200/400V 50Hz			6.4 / 3.2
HPV 100	3NS	5.0	1750	NEMA 184C	230/460V 60Hz	3	No	14.0 / 6.5
		3.7	1470		190/380V 50Hz			10.6 / 5.3
	3IS	5.5	1750	IEC DF112MC	230/460V 60Hz	3	No	14.0 / 7.0
4.1		1470	200/400V 50Hz		12.6 / 6.3			
HPV 125	3NS	7.5	1760	NEMA 213TC	208-230/460V 60Hz	3	No	22.0 / 11.0
			1470		190/380V 50Hz			18.0 / 9.0
HPV 150	3IS	7.5	1760	IEC DF132SC	230/460V 60Hz	3	No	18.4 / 9.2
			1470		200/400V 50Hz			16.8 / 8.4
HPV 250	3NS	10	1765	NEMA 215TC	208-230/460V 60Hz	3	Auto	26.8 / 13.4
			1470		190/380V 50Hz			31.2 / 15.6

HEAT-EXCHANGERS

Electrical rating may vary with motor manufacturer. Motor nameplates have actual ratings.
All standard models = Totally Enclosed Fan Cooled (TEFC)

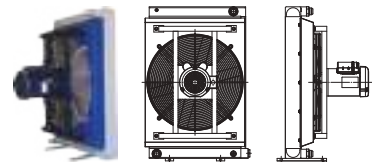

Optional Temperature Controls



Bimetallic monocontact thermo-switch series TM4/A1

TM4/A1 Series temperature switches are normally open. They close on rise when the fluid temperature: exceeds the higher set point (turning the fan on). They re-open at the lower set point (Turning the fan off). The 22° F hysteresis prevents the fan from over-cycling. The top of the switch may be rotated in 90° increments for ease of wiring.

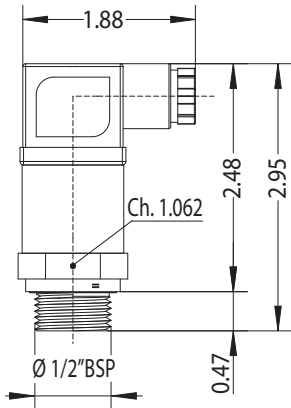

Technical Data

Working temperature : from -68°F to 248°F
Commutation frequency : 20 cycles/min
Switching accuracy : +/-7°F
Fixed hysteresis value : about 22°F
Body material : brass
Thread connection : ½ BSPP (seal included)
Max pressure : 2900 PSI
Mounting : in any position
Weight : 2.5 oz.

Electrical Data

Electrical connections : DIN 43650
Electrical protection : DIN 40050 IP65
Maximum contact load : 230V -10A & DC12V - 10A & DC24V - 5A
 Normally closed switches are available: Consult factory

Part Number	Temperature Range	Model Code Feature Adder
TM 44 / A1	104 - 82°F	- 1
TM 45 / A1	122 - 100°F	- 2
TM 46 / A1	140 - 118°F	- 3
TM 47 / A1	158 - 136°F	- 4
TM 48 / A1	176 - 154°F	- 5
TM 49 / A1	194 - 172°F	- 6

Normally closed switches are available: Consult factory.

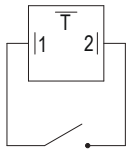

Optional Temperature Controls

Adjustable Thermostat TC2

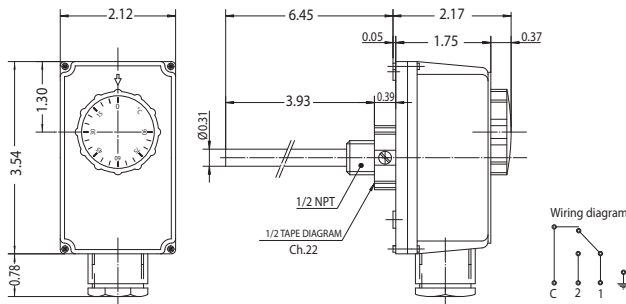

Part Number	Temperature range	Model Code Feature Adder
TC2 L100	0 - 194°F	- 8

Unipolar, liquid filled, encased, switch contacts, immersion thermostat, bulbwell included.

Technical Data

Differential: ΔT 5.4°F;
Contacts: Ag 1000/1000;
Maximum contact load 230V: 10A
 Switch of cutoff contacts loading;
Fairlead: PG9;
Max. head temperature: 176°F
Max. sensing bulb temperature: 266°F
Temperature rate of change: 1 K/min
Degree of protection: IP 40
Number of automatic cycles: II (100.000)



Adjustable Thermostat TC2 L= 39 inch

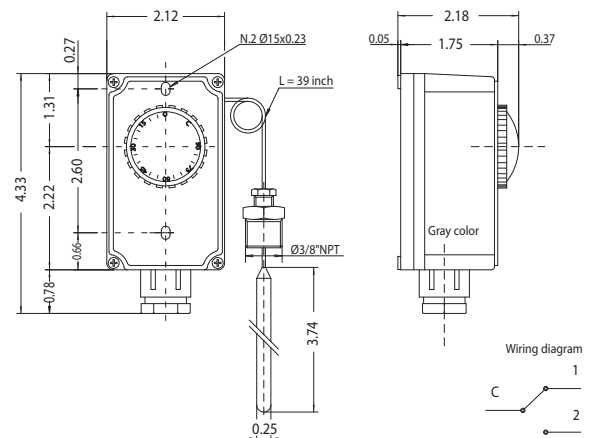

Part Number	Temperature range	Model Code Feature Adder
TC2 L39	0 - 194°F	- 9

Technical Data

Temperature range: 0 - 194°F
Differential: ΔT 5.4°F;
Contacts rating: 10(2.5)A/230V
Fairlead: M20x1.5 mm;
Max. head temperature: 176°F
Max. sensing bulb temperature: 302°F
Temperature rate of change: 1 K/min
Degree of protection: IP 40
 Silver contacts



Product Lines



AC Fan Driven



**2000K & KBV
AC Motors**
Heat Removals to 16 HP.
Optional Internal Bypass Valve.
Totally Enclosed Motors.
Oil Flows to 50 GPM.



**HPV Series I
AC Motors**
Heat Removals to 70 HP.
Internal Bypass Valve Standard.
Totally Enclosed Motors.
Oil Flows to 100 GPM.



**HPV Series II
AC Motors**
Heat Removals to 265 HP.
Internal Bypass Valve Standard.
Totally Enclosed Motors.
Oil Flows to 350 GPM.

DC Fan Driven



**2000K & KBV
DC Motors**
Heat Removals to 35 HP.
Optional Internal Bypass Valve.
Oil Flows to 125 GPM.



**HPV Series
DC Motors**
Heat Removals to 36 HP.
Internal Bypass Valve Standard.
Oil Flows to 80 GPM.



**S & SBV Series
DC Motors**
Heat Removals to 38 HP.
Optional Internal Bypass Valve.
Oil Flows to 100 GPM.

Hydraulic Fan Driven



**2000K & KBV
Hydraulic Motors**
Heat Removals to 30 HP.
Optional Internal Bypass Valve.
Wide range of Hydraulic Motor
Displacements available.
Oil Flows to 50 GPM.



**HPV Series I
Hydraulic Motors**
Heat Removals to 130 HP.
Internal Bypass Valve Standard.
Oil Flows to 100 GPM.



**HPV Series II
Hydraulic Motors**
Heat Removals to 300 HP.
Optional Internal Bypass Valve.
Oil Flows to 350 GPM.

Cooling Systems



Silent Evo II
Off-line cooling systems with
oil cooler & recirculation.
Pump heat removals to 60 HP.



RID Series
Gearbox cooling systems with oil
cooler, recirculation pump & filter
heat removals to 25 HP.



HPA TK
Combination reservoir, oil cooler,
& suction filter.
Ideal for closed loop hydrostatic
cooling.

Water / Oil



**WB Series
Water/Oil**
Stainless steel Water/Oil Coolers.
Compact water saving design.
Heat Removals to 360 HP.
Oil Flows to 200 GPM.



**MG Series
Water/Oil**
Sea Water duty shell & tube heat
exchangers.
Corrosion resistant copper-nickel
cooling tubes & bronze end
bonnets.



Water Modulating Valves
Control water flow through Water/Oil
heat exchangers to maintain desired
oil temperatures.
No external input required.

Accessories



AC Temperature Switches
Cycle cooling fan to maintain desired
temperatures.
Fixed & adjustable designs available.



DC Temperature Switches
12v & 24v Models.
TMR Switches are prewired & include
relay for plug & play operation.



Thermostatic Valves
Modulating valves bypass oil during
cold startup.
#8 through #24 sizes available.



HEAT-EXCHANGERS

Sales Network



USA

EMMEGI HEAT EXCHANGERS Inc.

(Main Office and Manufacturing)
3606 E. Southern Ave. Suite 2
Phoenix, AZ 85040 USA
Ph. + 1 602 438 7101
Fax + 1 602 438 7127
sales@emmegiinc.com
<http://www.emmegiinc.com>



SLOVAKIA

EMMEGI HEAT EXCHANGERS s.r.o.

Ul. M.Razusa 1
95514 Topolcany
Ph. + 421 387629212 - Fax + 421
387629222
<http://www.emmegi-heat-exchangers.com>
sro@emmegi-heat-exchangers.com



SWEDEN / FINLAND

EMMEGI HEAT EXCHANGERS
NORDIC AB.

Box 1136
262 22 ANGELHOLM
Visitors: Nybrovagen 4
Ph. + 46 (0) 431- 415096
Fax + 46 (0) 431- 415099
info.nordic@emmegi-heat-exchangers.com
<http://www.emmegi-heat-exchangers.com>



ASIA / PACIFIC

EMMEGI HEAT EXCHANGERS Ltd

Unit 17.9/ F.Corporation Park,
11 On Lai Street, Siu Lek Yuen,
Shatin, Hong Kong
Ph. + 852-26473488- Fax + 852-26032119
<http://www.emmegi-heat-exchangers.com>
emmegi@biznetvigator.com



GERMANY

EMMEGI GmbH

Philipp-Reis-Straße 2
41516 Grevenbroich-Kapellen
02182-570 18-0
02182-570 18-29
<http://www.emmegi-gmbh.de>
vertrieb@emmegi-gmbh.de

INDIA

EMMEGI INDIA Sales Office

B-37, DDA Shed
Okhla Industrial Area, Phase II
110020 NEW DELHI
+91 9810072019
+91 1141756320
<http://www.emmegi-heat-exchangers.com>
varun@emmegi-heat-exchangers.com

CHINA

EMMEGI HEAT EXCHANGERS

(Beijing) Co.,Ltd.
Unit 706,7/ F. Building A, China
Foreign Language Mansion,
89 West, 3 rd Ring (N) Road,
Haidian District,Beijing,
PR.China,Post code: 100089
Ph. + 86 10 88820971- Fax + 86 10 88820972
<http://www.emmegi-heat-exchangers.com>
emmegi@vip.sina.com

UK

EMMEGI UK

(Sales Office)
Evergreen, The Reddings
Cheltenham GL51 6RL
Ph. + 44 1242700151
Fax + 44 8707577659
sales@emmegi.co.uk
<http://www.emmegi.co.uk>

Headquarters



ITALIA

EMMEGI S.p.A.
Via Newton,52 - Zona Industriale
20062 Cassano d'Adda (MI) - Italy
Tel. +39 0363 360236 - Fax + 39 0363 360230
<http://www.emmegi-heat-exchangers.com>
info@emmegi-heat-exchangers.com

