

### DESCRIPTION

Rodless cylinders series "Z" are suitable for applications where long strokes are required, as they have been designed with reduced overall dimensions if compared to the standard cylinders with external rod. The short cylinder (version "K") has a basic length (0-stroke) up to 40% shorter than the "S" standard version. The guided versions (options "F" & "FF") allow the translation of non-guided loads and offer great resistance to transversal forces. Cylinders series "Z" are supplied with magnetic piston type as standard and, upon request, comply with ATEX directive, 2G category.



### TECHNICAL DATA

Operating pressure	2 ÷ 8 bar
Working temperature	0 ÷ +80 °C (-20 °C with dry air)
Fluid	Filtered, unlubricated, continuous lubricated or dry compressed air
Versions	Standard yoke, short yoke
Bore	Ø 18, 25, 32, 40, 50, 63
Port size	Ø 18 = M5 Ø 25 - 32 = G 1/8 Ø 40 - 50 = G 1/4 Ø 63 = G 3/8
Decelerators length	Ø 18 25 32 40 50 63 mm 15 18 24 34 40 49
Maximum strokes (mm)	Ø 18 ÷ 63 = 6000

P.S.: in the Ø 18 size, it's not possible to mount the magnetic sensors series "FM100" in the opposite side of the yoke.

### MATERIALS

End caps	Anodized aluminium alloy
Cylinder barrel	Extruded profile, anodized aluminium alloy
Sealing strip	Polyamide
Cover strip	AISI 304 stainless steel
Head wiper	Acetal resin
Piston	Aluminium alloy with piston seal in acetal resin
Yoke	Anodized aluminium alloy
Decelerators ogives	Brass
Seals	Polyurethane

### ORDER KEY

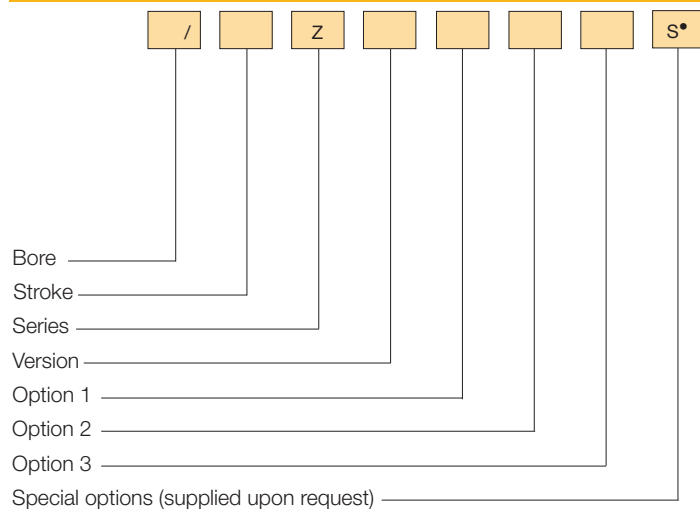

• See Chapter 1 on page 1.1.

### ORDER EXAMPLES

Rodless cylinder Ø 50, 500 mm stroke, with standard yoke and ports:  
**50/500 ZS**

Rodless cylinder Ø 40, 1000 mm stroke, short yoke, single guide, one side ports: **40/1000 ZKF1**

Rodless cylinder Ø 32, 1000 mm stroke, short yoke, double guide, one side ports, ATEX: **32/1000 ZKFF1**

### VERSION

**S** Standard yoke                      **K** Short yoke

### OPTION 1

**F** Single guide                          **FF** Double guide\*

### OPTION 2

**1** One side ports\*\*                      **2** Bottom ported\*\*

### OPTION 3

/EX Consistent with the ATEX directive  II 2G c T5 -20°C<Ta<80°C

\*\* Supplied only for "S" version

\*\* Supplied from Ø 25 to Ø 63

### SPARE PARTS

Seals kit - Polyurethane	<b>Ø/SG/Z</b>
Sealing strip (min. 500 mm)	<b>Ø/BP/Z/mm</b>
Cover strip (min. 500 mm)	<b>Ø/BM/Z/mm</b>

## TECHNICAL INFORMATION

### MAXIMUM PERMISSIBLE FORCES

Ø	F <sub>x</sub> in (N) a 6 bar - speed ≤ 0,35 m/s					F <sub>z</sub> in (N) - speed ≤ 0,35 m/s					F <sub>y</sub> in (N) - speed ≤ 0,35 m/s				
	ZS	ZK	ZSF	ZSFF	ZKF	ZS	ZK	ZSF	ZSFF	ZKF	ZS	ZK	ZSF	ZSFF	ZKF
18	140	140	140	140	140	300	140	370	550	150	80	40	370	550	150
25	270	270	270	270	270	480	230	800	1200	250	110	55	800	1200	250
32	440	440	440	440	440	650	320	1200	1800	450	165	70	1200	1800	450
40	680	680	680	680	680	800	400	1600	2400	600	225	100	1600	2400	600
50	1060	1060	1060	1060	1060	1060	480	2100	3200	900	325	140	2100	3200	900
63	1680	1680	1680	1680	1680	1680	590	2800	4200	1100	435	180	2800	4200	1100

Ø	Speed = 0,75 m/s					Speed = 1 m/s					Speed = 1,5 m/s				
	ZS	ZK	ZSF	ZSFF	ZKF	ZS	ZK	ZSF	ZSFF	ZKF	ZS	ZK	ZSF	ZSFF	ZKF
18	80	40	100	150	50	40	25	58	80	30	20	10	26	20	12
25	155	90	280	420	100	90	50	160	210	60	40	25	65	80	30
32	280	200	510	750	250	155	110	300	400	135	70	45	140	170	65
40	500	420	1000	1500	480	290	240	550	750	280	125	110	250	300	140
50	790	750	1500	2200	800	420	440	850	1150	480	195	190	380	460	220
63	1500	1500	2500	3700	1500	850	850	1400	1900	950	370	380	610	740	400

P.S.:  $\Sigma F = \text{Resultant force} = \sqrt{F_x^2 + F_z^2 + F_y^2}$

### MAXIMUM PERMISSIBLE TORQUE

Ø	M <sub>x</sub> in (Nm)					M <sub>z</sub> in (Nm)					M <sub>y</sub> in (Nm)				
	ZS	ZK	ZSF	ZSFF	ZKF	ZS	ZK	ZSF	ZSFF	ZKF	ZS	ZK	ZSF	ZSFF	ZKF
18	1	0,4	3,5	5,2	1,8	3	1,7	6	9	1,8	3	1,7	6	9	1,8
25	2	0,7	10	15	4	13	2,7	20	30	4	13	2,7	20	30	4
32	3,5	1	25	37	10	25	5	45	67	10	25	5	45	67	10
40	5,5	2	40	60	16	40	8,5	75	110	16	40	8,5	75	110	16
50	10	3,5	80	120	30	65	13	150	220	30	65	13	150	220	30
63	16	5	110	170	45	100	18	250	370	45	100	18	250	370	45

### MAXIMUM PERMISSIBLE FORCE "Fz" (as a function of the distance "L" between supports and of the deflection request)

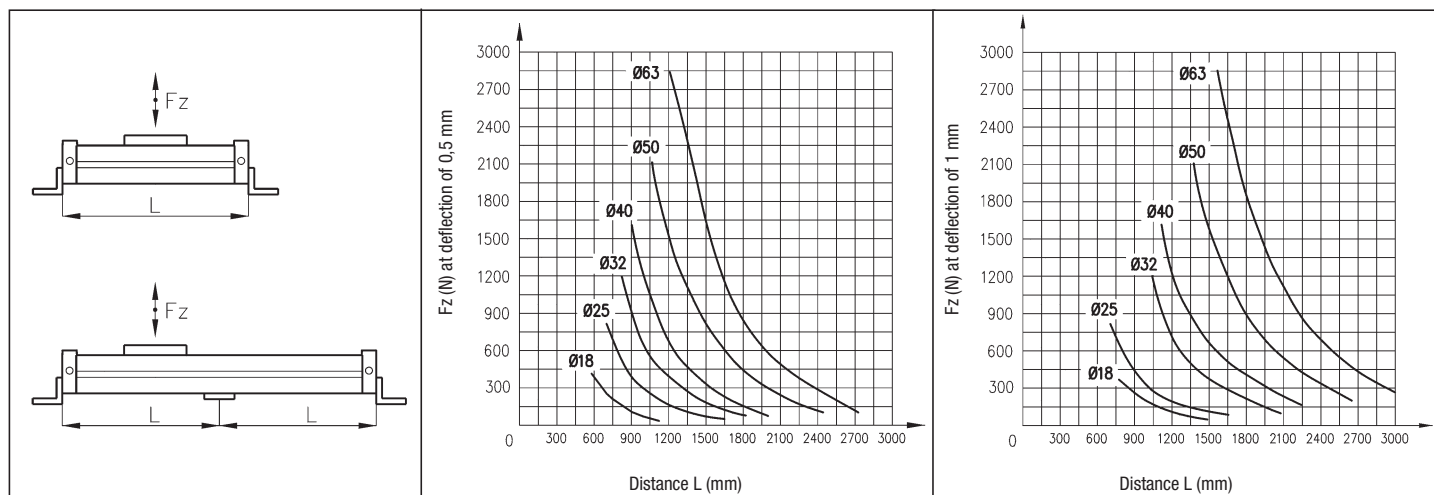

## ZS BASIC CYLINDER WITH STANDARD YOKE

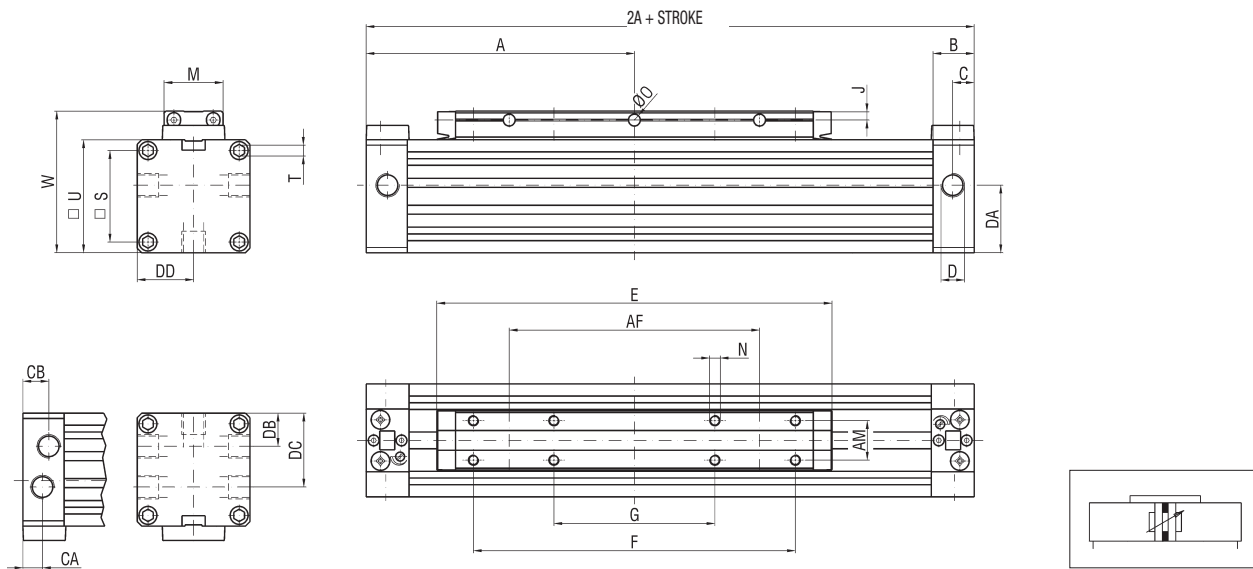

### DIMENSIONS AND WEIGHTS ZS BASIC CYLINDER

Ø	A	AF	AM	B	C	CA	CB	D	DA	DB	DC	DD	E	F	G	J	M	N	O	S	T	U	W	WEIGHT (g)	INCR. (g) x10 mm
18	80	50	10	16,5	6,5	-	-	M5	17,5	-	-	15	103	75	-	3	15,5	M3x6	3,5	23,5	M3x7	30	39	300	15
25	100	70	13	20	8,5	7	13	G1/8	25,5	14	28	21	131	100	50	3,5	20	M4x7	4,5	33	M4x9	42	53	600	26
32	120	100	16	20	8,5	7	13	G1/8	32	17,5	34,5	26	171	140	70	4,5	25	M5x9	5,5	41	M5x10	52	65	1100	36
40	150	140	22	24	11	9,5	14,5	G1/4	37,5	20	42	31,5	220	180	90	5	33	M6x10	7	51	M6x12	63	79	1800	48
50	180	180	29	24	11	9,5	14,5	G1/4	47,5	26	52	39	280	220	110	6,5	42	M8x12,5	7	63	M8x12	78	96	3200	74
63	215	230	40	30	14,5	11	18,5	G3/8	59,5	30	62	46,5	333	280	140	8	54	M8x15	9	78	M8x12	93	113,5	5600	100

## ZK BASIC CYLINDER WITH SHORT YOKE

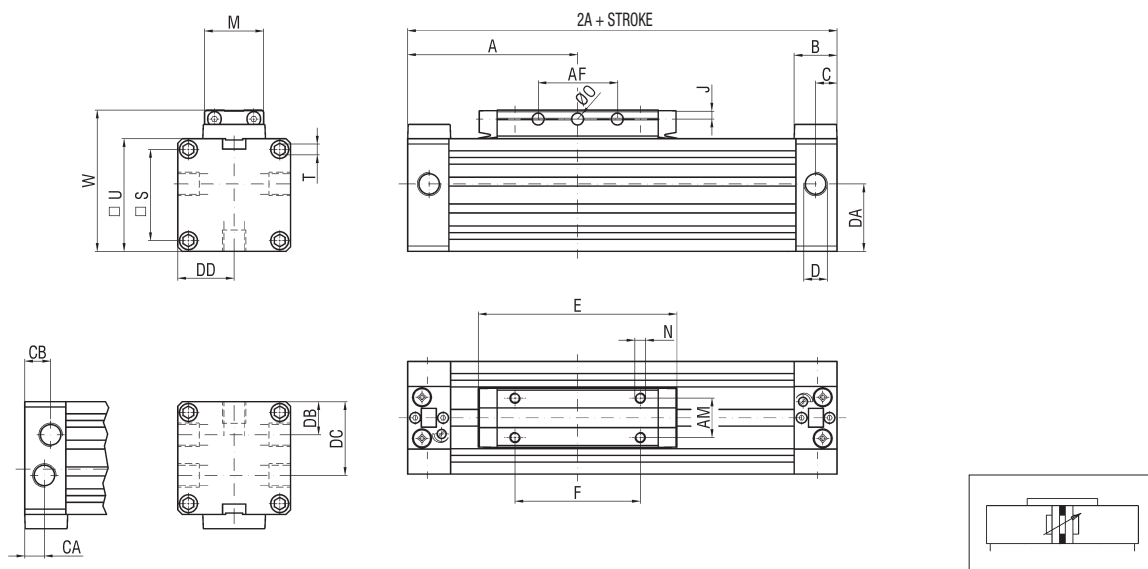

### DIMENSIONS AND WEIGHTS ZK BASIC CYLINDER

Ø	A	AM	B	C	CA	CB	D	DA	DB	DC	DD	E	F	J	M	N	O	S	T	U	W	WEIGHT (g)	INCR. (g) x10 mm
18	57,5	10	16,5	6,5	-	-	M5	17,5	-	-	15	58	30	3	15,5	M3x6	3,5	23,5	M3x7	30	39	200	15
25	67,5	13	20	8,5	7	13	G1/8	25,5	14	28	21	66	35	3,5	20	M4x7	4,5	33	M4x9	42	53	400	26
32	77,5	16	20	8,5	7	13	G1/8	32	17,5	34,5	26	86	55	4,5	25	M5x9	5,5	41	M5x10	52	65	700	36
40	95	22	24	11	9,5	14,5	G1/4	37,5	20	42	31,5	110	70	5	33	M6x10	7	51	M6x12	63	79	1200	48
50	105	29	24	11	9,5	14,5	G1/4	47,5	26	52	39	130	70	6,5	42	M8x12,5	7	63	M8x12	78	96	2000	74
63	125	40	30	14,5	11	18,5	G3/8	59,5	30	62	46,5	153	100	8	54	M8x15	9	78	M8x12	93	113,5	3200	100

ZSF BASIC CYLINDER WITH STANDARD YOKE AND SINGLE GUIDE

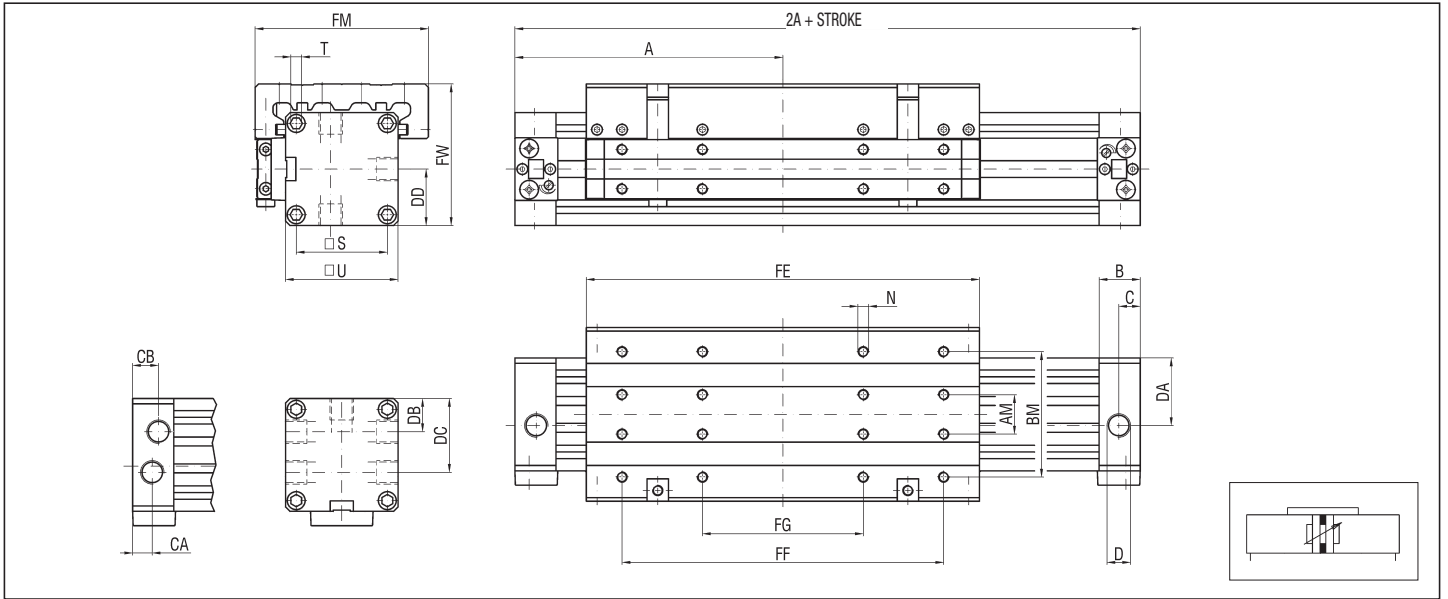

DIMENSIONS AND WEIGHTS ZSF BASIC CYLINDER

Ø	A	AM	B	BM	C	CA	CB	D	DA	DB	DC	DD	FE	FF	FG	FM	FW	N	S	T	U	WEIGHT (g)	INCR. (g) x10 mm
18	80	10	16,5	35	6,5	-	-	M5	17,5	-	-	15	103	75	-	50	39	M4x7,5	23,5	M3x7	30	400	15
25	100	13	20	45	8,5	7	13	G1/8	25,5	14	28	21	131	100	50	66	53	M4x8	33	M4x9	42	900	26
32	120	16	20	55	8,5	7	13	G1/8	32	17,5	34,5	26	171	140	70	80	65	M5x10	41	M5x10	52	1500	36
40	150	22	24	70	11	9,5	14,5	G1/4	37,5	20	42	31,5	220	180	90	97	79	M6x12	51	M6x12	63	2800	48
50	180	29	24	85	11	9,5	14,5	G1/4	47,5	26	52	39	280	220	110	116	96	M8x16	63	M8x12	78	4900	74
63	215	40	30	105	14,5	11	18,5	G3/8	59,5	30	62	46,5	333	280	140	136	113,5	M8x16	78	M8x12	93	8000	100

ZSFF BASIC CYLINDER WITH STANDARD YOKE AND DOUBLE GUIDE

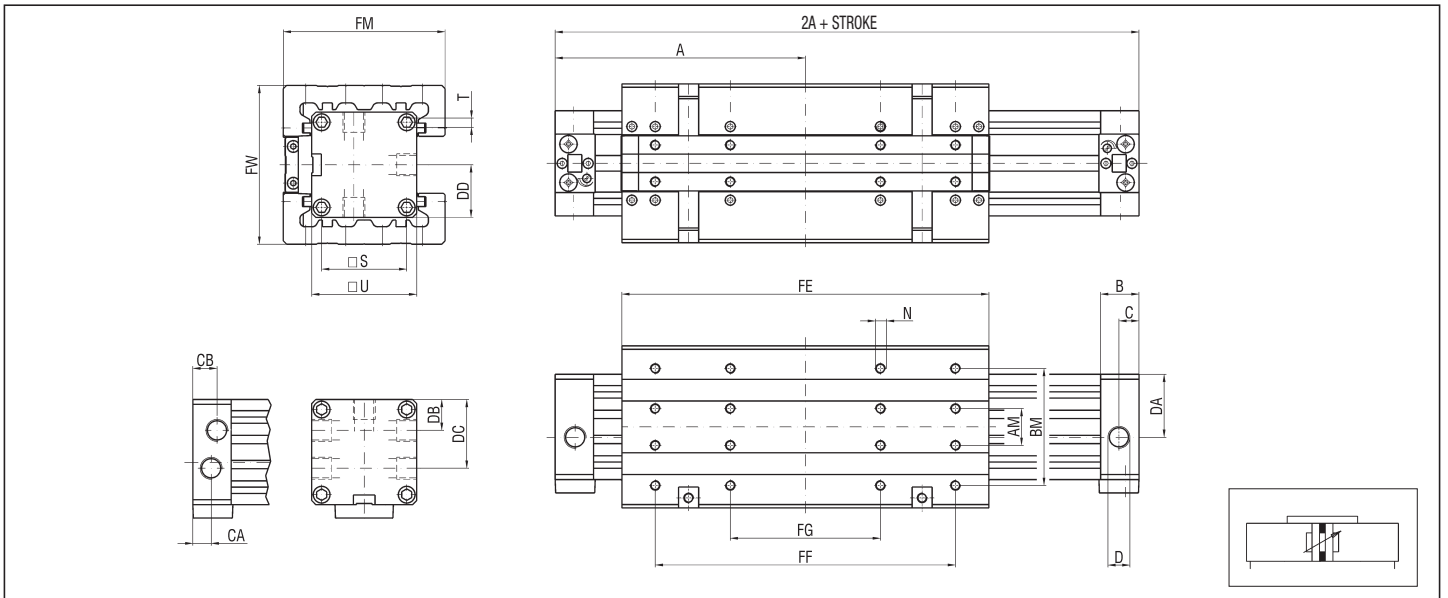

DIMENSIONS AND WEIGHTS ZSFF BASIC CYLINDER

Ø	A	AM	B	BM	C	CA	CB	D	DA	DB	DC	DD	FE	FF	FG	FM	FW	N	S	T	U	WEIGHT (g)	INCR. (g) x10 mm
18	80	10	16,5	35	6,5	-	-	M5	17,5	-	-	15	103	75	-	50	50	M4x7,5	23,5	M3x7	30	500	15
25	100	13	20	45	8,5	7	13	G1/8	25,5	14	28	21	131	100	50	66	64	M4x8	33	M4x9	42	1200	26
32	120	16	20	55	8,5	7	13	G1/8	32	17,5	34,5	26	171	140	70	80	78	M5x10	41	M5x10	52	1900	36
40	150	22	24	70	11	9,5	14,5	G1/4	37,5	20	42	31,5	220	180	90	97	95	M6x12	51	M6x12	63	3800	48
50	180	29	24	85	11	9,5	14,5	G1/4	47,5	26	52	39	280	220	110	116	114	M8x16	63	M8x12	78	6600	74
63	215	40	30	105	14,5	11	18,5	G3/8	59,5	30	62	46,5	333	280	140	136	134	M8x16	78	M8x12	93	10400	100

## ZKF BASIC CYLINDER WITH SHORT YOKE AND SINGLE GUIDE

1

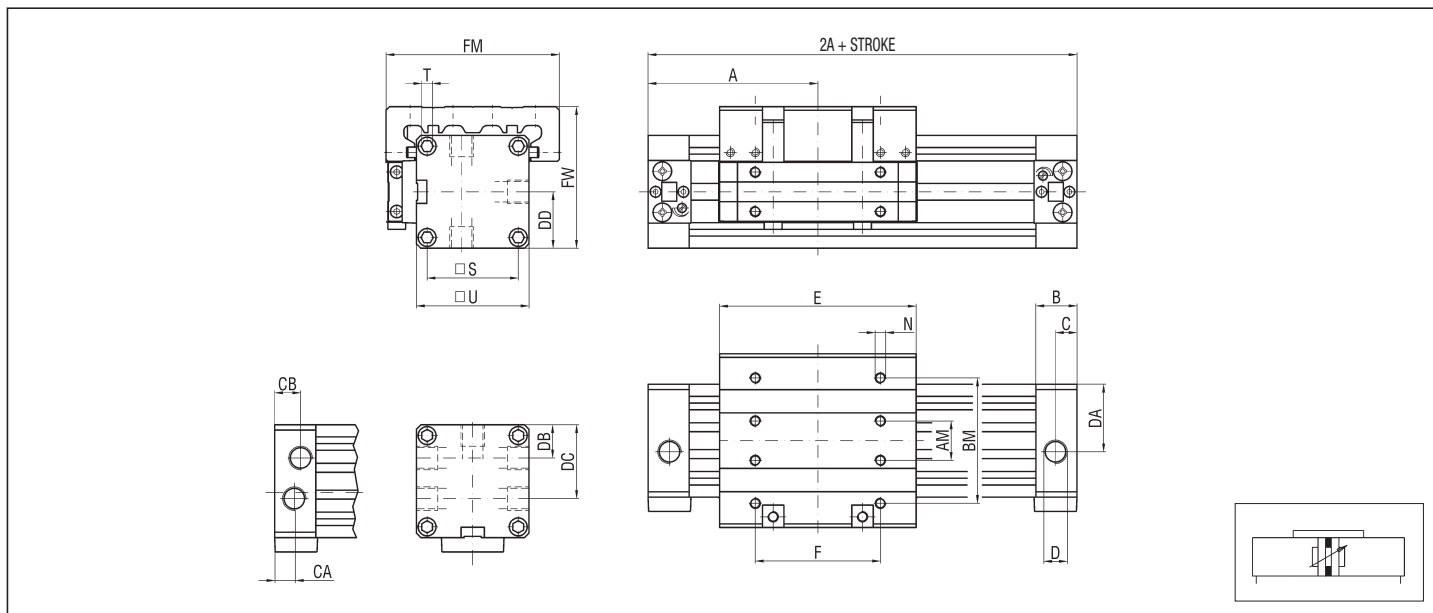

## DIMENSIONS AND WEIGHTS ZKF BASIC CYLINDER

Ø	A	AM	B	BM	C	CA	CB	D	DA	DB	DC	DD	E	F	FM	FW	N	S	T	U	WEIGHT (g)	INCR. (g) x10 mm
18	57,5	10	16,5	35	6,5	-	-	M5	17,5	-	-	15	58	30	50	39	M4x7,5	23,5	M3x7	30	300	15
25	67,5	13	20	45	8,5	7	13	G1/8	25,5	14	28	21	66	35	66	53	M4x8	33	M4x9	42	600	26
32	77,5	16	20	55	8,5	7	13	G1/8	32	17,5	34,5	26	86	55	80	65	M5x10	41	M5x10	52	1150	36
40	95	22	24	70	11	9,5	14,5	G1/4	37,5	20	42	31,5	110	70	97	79	M6x12	51	M6x12	63	2000	48
50	105	29	24	85	11	9,5	14,5	G1/4	47,5	26	52	39	130	70	116	96	M8x16	63	M8x12	78	3200	74
63	125	40	30	105	14,5	11	18,5	G3/8	59,5	30	62	46,5	153	100	136	113,5	M8x16	78	M8x12	93	6400	100

FEET (PAIR) - ALUMINIUM - ZPB Ø

Ø	AA	AB	AC	AD	AE	AH	WEIGHT (g)
18	15	2	10	20	6	2	35
25	18	2	12,5	30	6	2	40
32	20	2,5	13,5	40	7	3	75
40	25	2,5	17,5	50	9	3	115
50	28	3	20	60	9	3	225
63	30	3	21	75	11	4,5	280

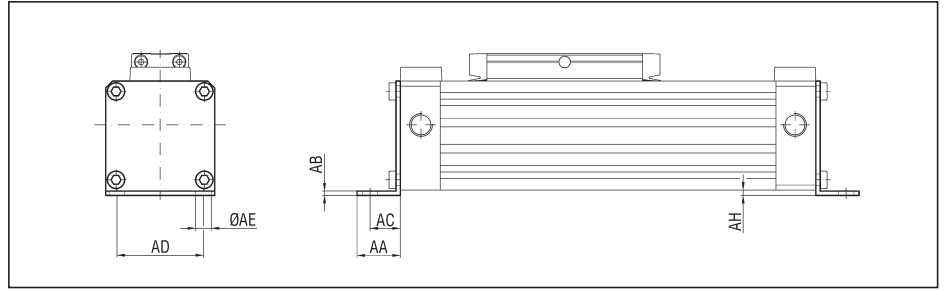

MIDDLE SUPPORTS (PAIR) - ALUMINIUM - ZTI Ø

Ø	AE	AH	BA	BB	BC	BD	BE	BF	WEIGHT (g)
18	6	2	56	46	36,5	23	2,5	8,25	10
25	6	2	70	60	50	28	3,5	11	15
32	7	3	85	73	61,5	33	4	13,8	30
40	9	3	105	90	75	38	4,5	16	45
50	9	3	122	106	91	43	5	19	60
63	11	4,5	144	125	107	48	6	22	80

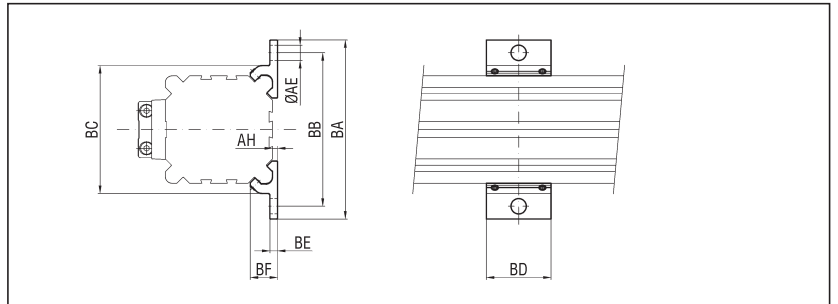

NARROW SWINGING BRIDGE - ALUMINIUM - ZCS Ø

Ø	CA	CB	CC	CD	CE	CF	CG	CK
18	50	25,5	30	9	M5	54	2,5	M4
25	60	30	40	14	M5	70	3	M4
32	70	37	50	16	M6	86	3,5	M5
40	80	47	60	22	M8	107	4,5	M6
50	90	56	70	30	M8	123	4,5	M6
63	100	73	80	40	M10	145,5	5	M8

Ø	CJ	CH	WEIGHT (g)
18	4	4	45
25	4	4	60
32	6	6	115
40	8	8	220
50	8	8	275
63	8	8	470

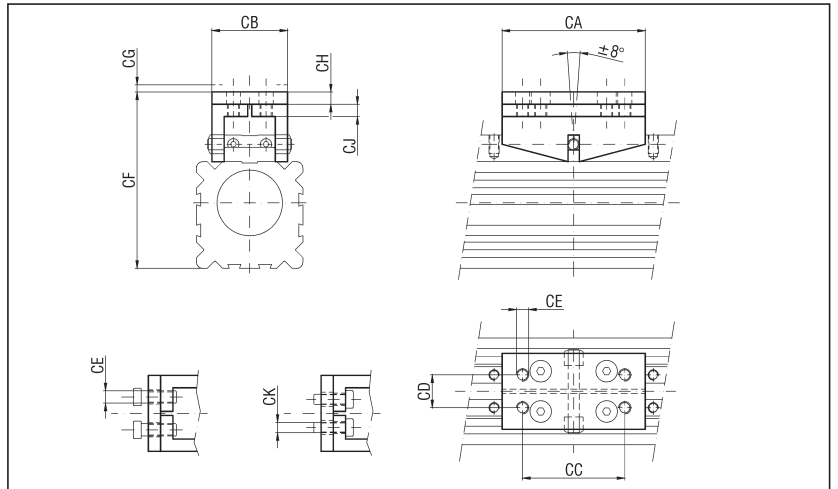

LARGE SWINGING BRIDGE - ALUMINIUM - ZCL Ø

Ø	CA	CB	CC	CD	CE	CF	CG	CK
18	50	41,5	30	34	M5	54	2,5	M4
25	60	50	40	38	M5	70	3	M4
32	70	60	50	48	M6	86	3,5	M5
40	80	80	60	60	M8	107	4,5	M6
50	90	95	70	70	M8	123	4,5	M6
63	100	120	80	80	M10	145,5	5	M8

Ø	CJ	CH	WEIGHT (g)
18	4	4	50
25	4	4	80
32	6	6	145
40	8	8	275
50	8	8	350
63	8	8	575

